

## Installation guide

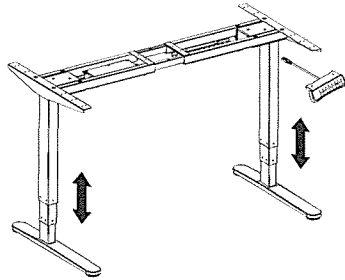

### Technical data

Column stage	3	Input Voltage	100-240V
Max. Weight Capacity	125KG	Max Speed	38mm/s
Height range	620-1250mm	Temperature	0-40°C
Length range	1100-1800mm	Certification	CE FCC CUL
Duty cycle	10%, Max. 2 min on/ Min. 18 min off		

### Accessory list

Attention: The drawings below are only for reference which might be slightly different from the actual object, please in kind prevail. Any tools missing or installation problems, please contact the customer service firstly.

No.	Image	Spec	Qty
A		M6x16mm	8
B		ST4.2x20mm	26
C		M8x35mm	8
D		Square spacer	6
E		Wrench 4x4mm      Wrench 5x5mm	1

### STEP 1

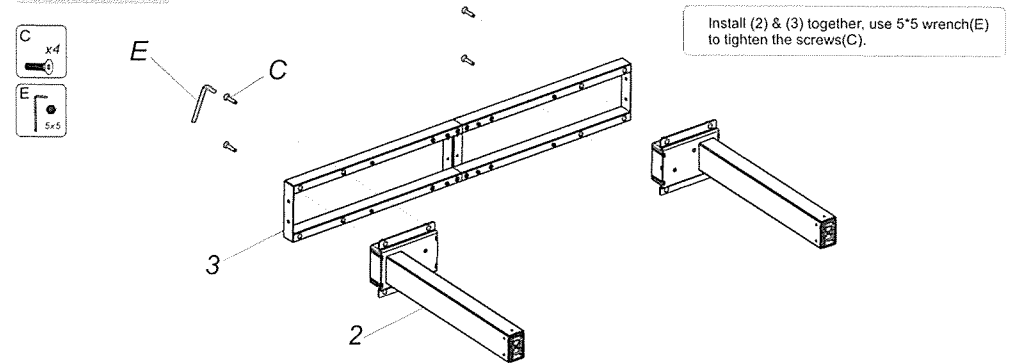

### STEP 2

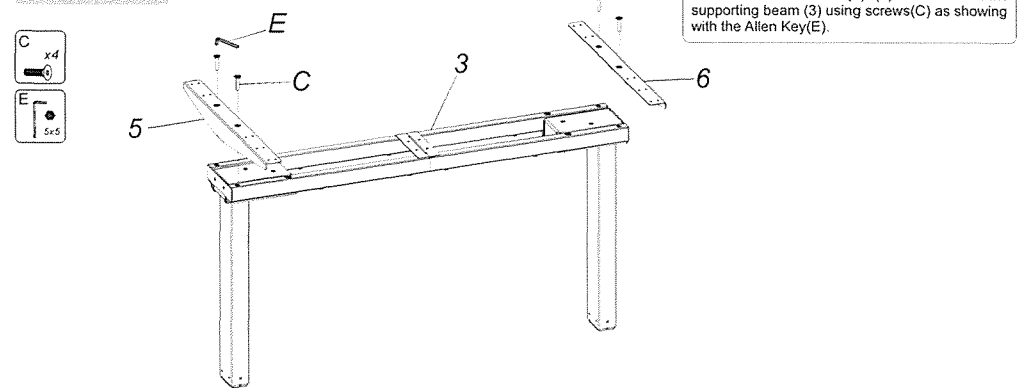

### STEP 3

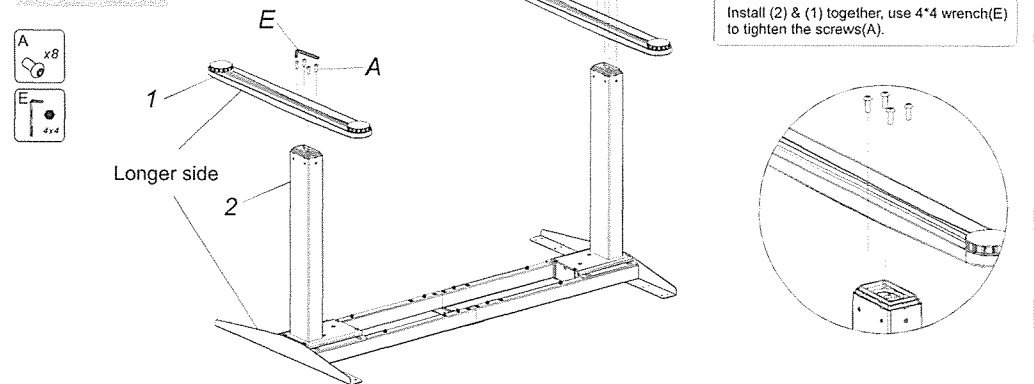

### Component list

No.	Part	Qty	No.	Part	Qty
①	Feet	2	②	Lifting Column	2
No.	Part	Qty	No.	Part	Qty
③	Supporting Beam	1	④	Cable Management Tray	2
No.	Part	Qty	No.	Part	Qty
⑤	Left Supporting Beam	1	⑥	Right Supporting Beam	1
No.	Part	Qty	No.	Part	Qty
⑦	Control box	1	⑧	Hand Switch	1
No.	Part	Qty			
⑨	Power Plug	1			

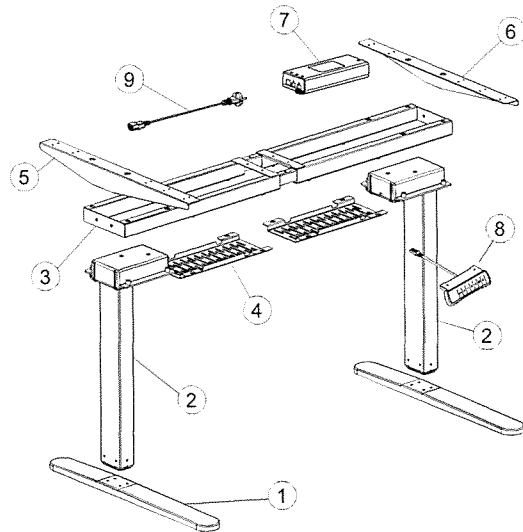

### STEP 4

Install the Tabletop

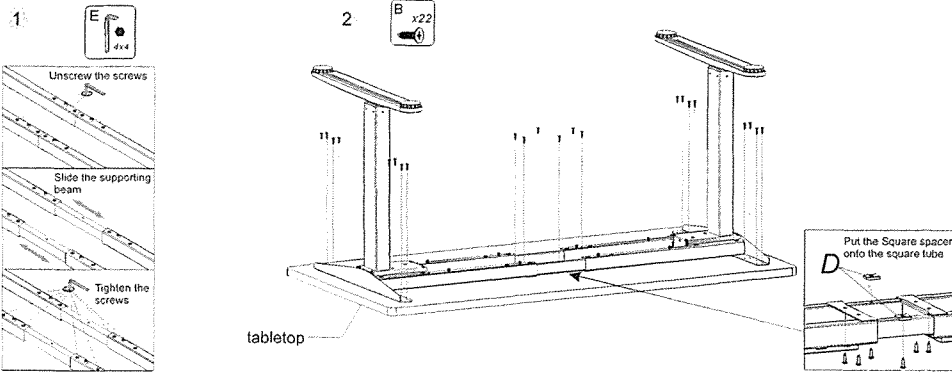

### STEP 7

Install the cable management tray(4)

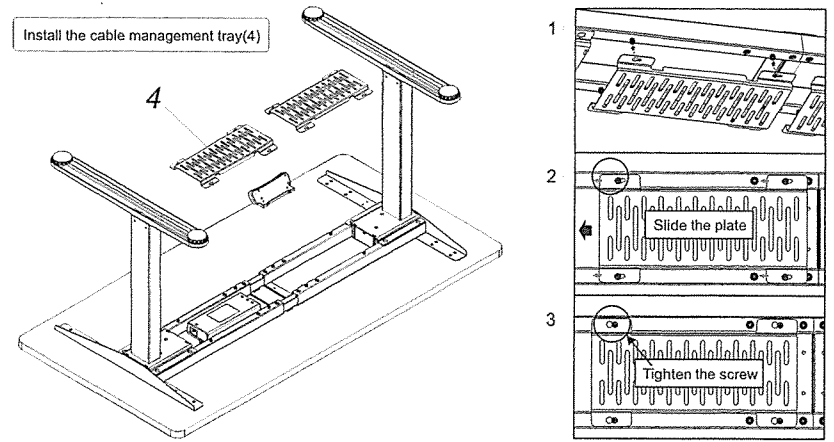

### STEP 5

Install the Control Box(7) and the Hand Switch(8)

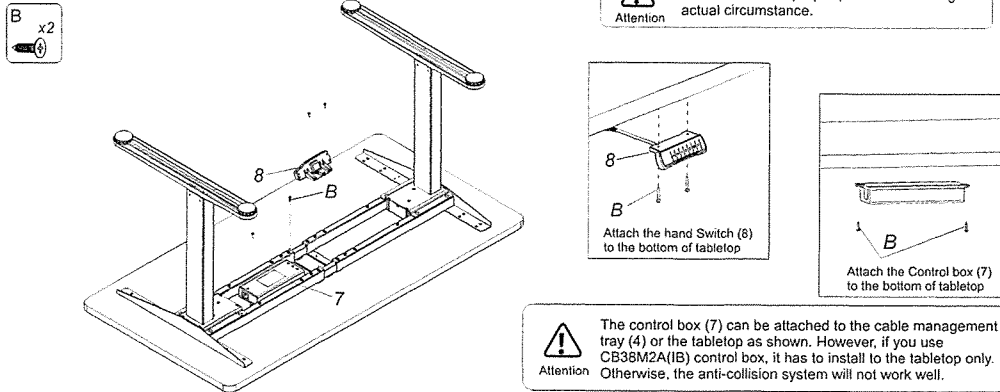

Please choose a proper position according to actual circumstance.



The control box (7) can be attached to the cable management tray (4) or the tabletop as shown. However, if you use CB38M2A(IB) control box, it has to install to the tabletop only. Otherwise, the anti-collision system will not work well.

### Common fault treatment

The following tips will help you detected and eliminate the common fault and error. If the fault you met is not listed below, please contact with your supplier. Only the manufacturer and professionals are capable for investigating and correcting those fault and error.

Fault phenomenon	Method
No response while long pressing down arrow after connected with a power supply	1. Check if all the cables be connected well 2. Contact your supplier or dealer
No response while pressing up arrow/down arrow after connected with a power supply	1. Check if all the cables be connected well 2. Contact your supplier or dealer
Rising in a low speed	1. Check if overloaded, max loading: 125kg; 2. Contact your supplier or dealer
The motor not move as instructed	1. Contact your supplier or dealer
Go down but not go up	1. Reposition 2. Contact your supplier or dealer
Downward sliding	1. Check if overloaded, max loading: 125kg. 2. Contact your supplier or dealer
Frequently Reposition	1. Check if overloaded, max loading: 125kg 2. Contact your supplier or dealer
Overwork (Duty cycle: Max 2min on/18min OFF)	1. Restart after suspend for 18mins while continuing with power. 2. Contact your supplier or dealer.
Not enough up&down height	1. Press "M" and "3" together for 3 seconds or more, after hearing continuous beeping for twice, it will restore factory settings. 2. Contact your supplier or dealer



### Attention

- Power supply: AC100V-240V,50/60Hz
- Service Environment: 0-40°C
- Unplug the power plug before cleaning, wipe the dust on surface with slight wet dishcloth when cleaning, be careful not to let the drops into the internal parts, not loose the connector.
- The electric box contains electronic components, metals, plastics, wires etc., so dispose of it in accordance with each country's environmental legislation, not the general household waste.
- Check carefully to ensure correct and complete assembly before using.
- Be familiar with all functions and program settings of the product before first use.
- Children are forbidden to play on the product because of unforeseen action when playing, so any dangerous consequences caused by this improper action will not be on
- Slight noise caused by the V-ribbed belt or brake system due to structure will not have any effect on the use of the equipment.
- Corrosive or abrasive materials are forbidden to clean the equipment. Must ensure that the cleaner used will not pollute the environment.
- This appliance can be used by children aged from 8 years and above and persons with reduced physical, sensory or mental capabilities or lack of experience and knowledge if they have been given supervision or instruction concerning use of the appliance in a safe way and understand the hazards involved. Children shall not play with the appliance.
- Cleaning and user maintenance shall not be made by children without supervision.
- If the supply cord is damaged, it must be replaced by the manufacturer, its service agent or a similarly qualified person in order to avoid a hazard.
- Please make sure there is no hazard sources in your operating environment, e.g., do not litter the tools around. Always be careful to treat the packaging materials in order to avoid any possible danger, e.g. plastic bag may lead to choking hazard to children.
- Keep the original package of the equipment if necessary in case of the future use in transportation.

### STEP 6

Connect all the cables onto the control box(7)

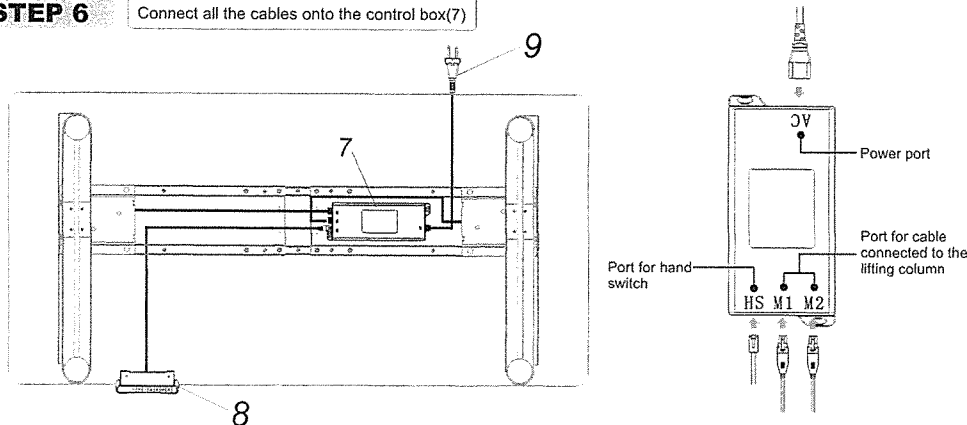

### Waste disposal

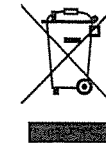

This marking indicates that this product should not be disposed with other household wastes. To prevent possible harm to the environment or human health from uncontrolled waste disposal, recycle it responsibly to promote the sustainable reuse of material resources. To return your used device, please use the return and collection systems or contact the retailer where the product was purchased. They can take this product for environmental safe recycling.