

# Screen (all sizes) Assembly Instructions

1: Remove the screen from the carton

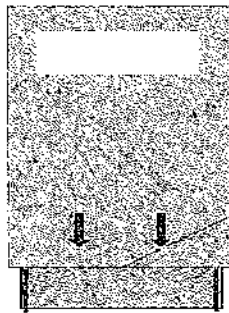

Arrows pointing down

2: Remove the top cap from the side to be joined

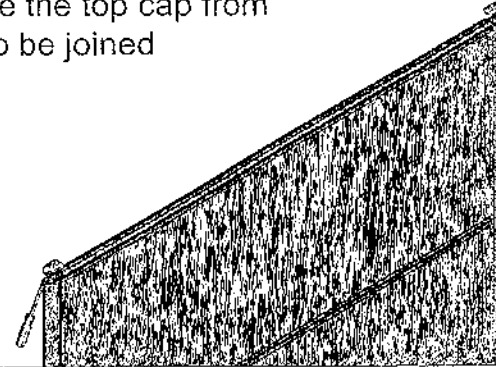

3: Remove the joining pole top cap, and joining strips from pole

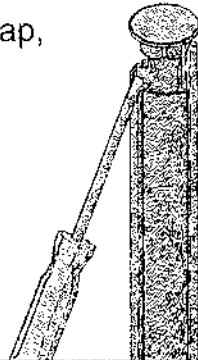

4: Align pole and screen joining grooves and insert aluminium joining strips. Be sure to ensure that both pole and screen are aligned down their entire length to ensure easy entry of the joining strip, it should not need to be forced and should insert easily with a small shake of the screen.

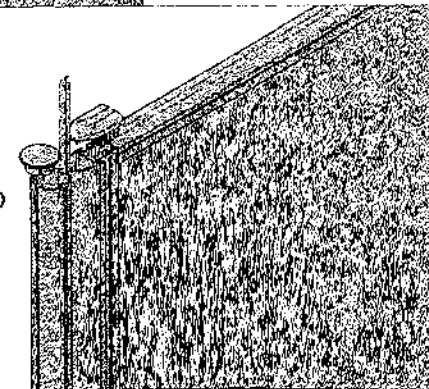

5: Add the required number of screens to the joining pole

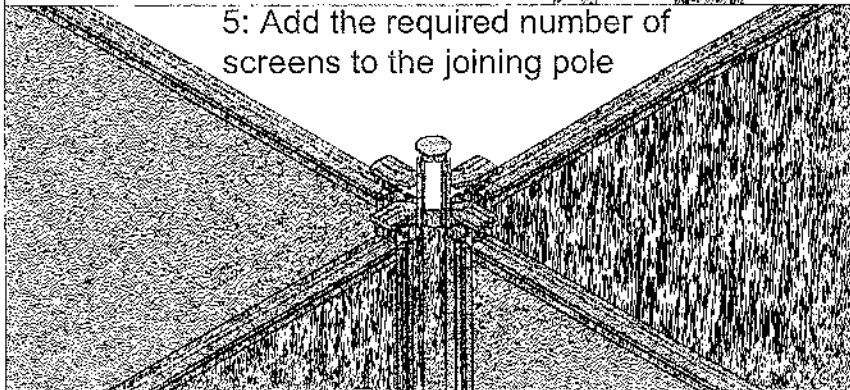

6: Replace the top caps to both the screen and pole, and adjust finished screen height using the supplied foot adjusting spanner.

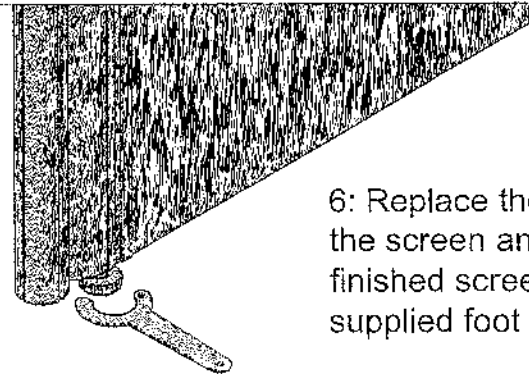

# SCREEN POLE (both heights) ASSEMBLY INSTRUCTIONS

Step 1 Remove the pole from the box

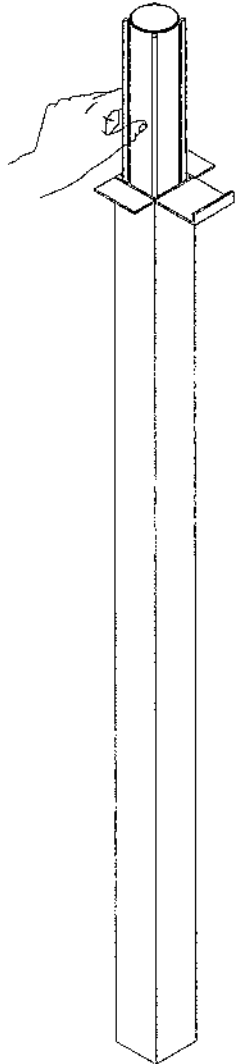

Step 2 Remove the cap from pole using a flat screwdriver

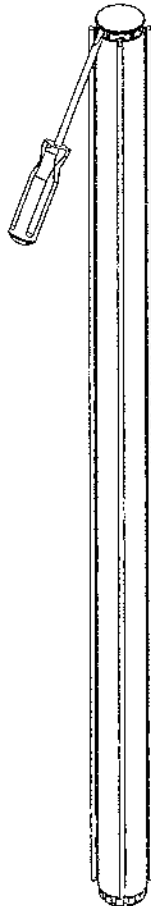

Step 3 Remove connectors from pole

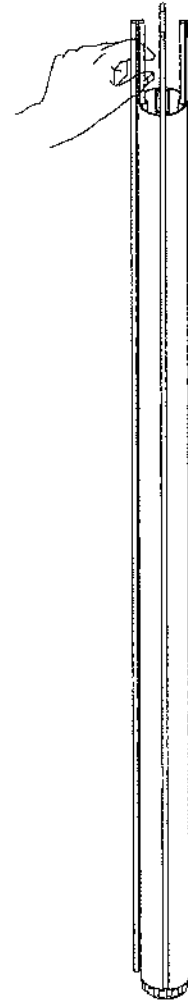

Step 4 Once required number of screens are attached, replace cap.

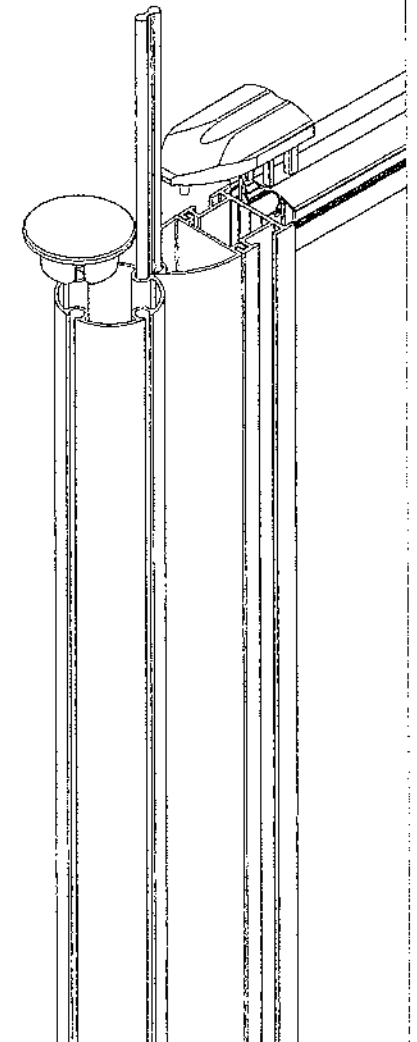

# Assembly Instructions

## BRACKETS



Pictured: 2 x Sets of 2 brackets

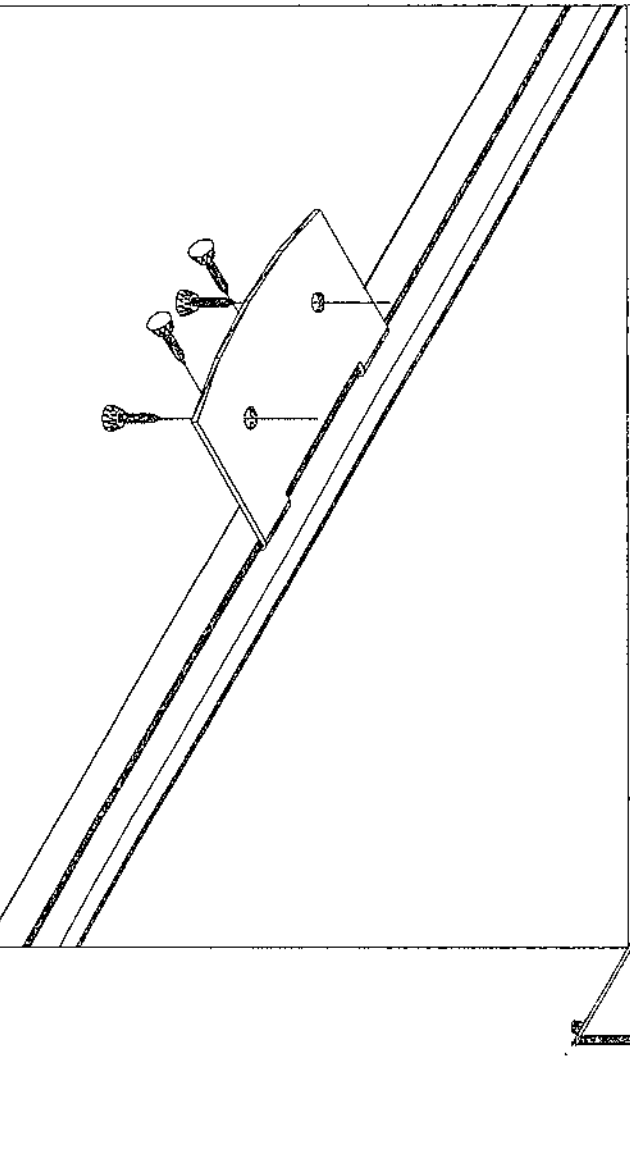
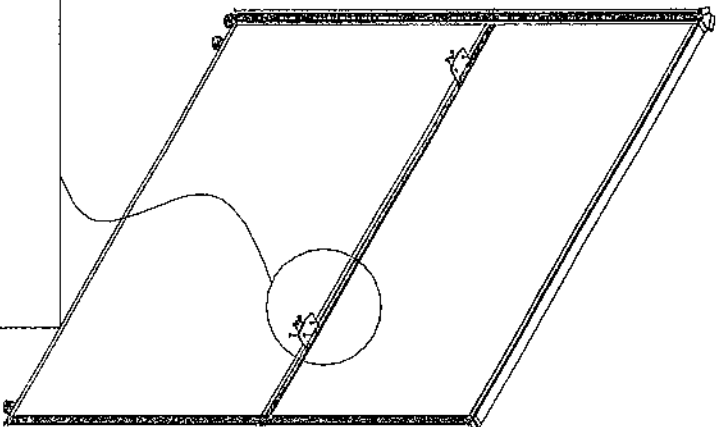

1. Use 2 x provided screws to attach the plate to the screen
2. Use 2 x provided screws to attach the top to the plate

Comes with:

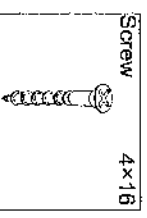

Fixing Plate  
Set of 2



### IMPORTANT NOTE:

- Place all laminated parts on a clean and smooth surface such as a rug or carpet to avoid the parts from being scratched.
- Check to be sure that you have all parts and hardware.
- Remove all wrapping materials, including staples & packing straps before you start to assemble.
- Don't tighten all screws/bolts until all completely assembled.
- Keep all hardware parts out of reach of children



# Assembly Instructions

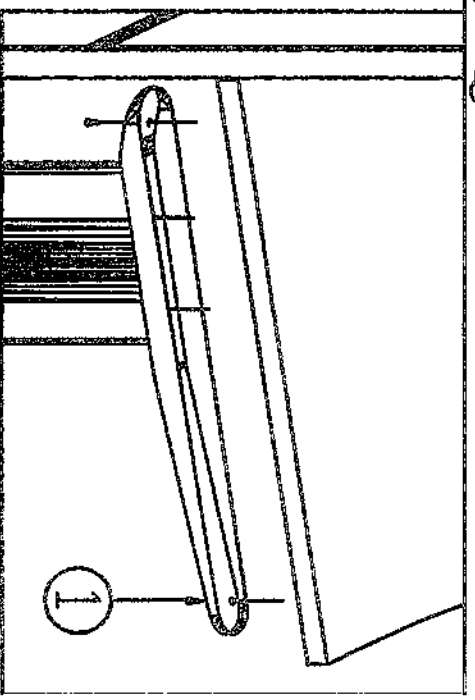
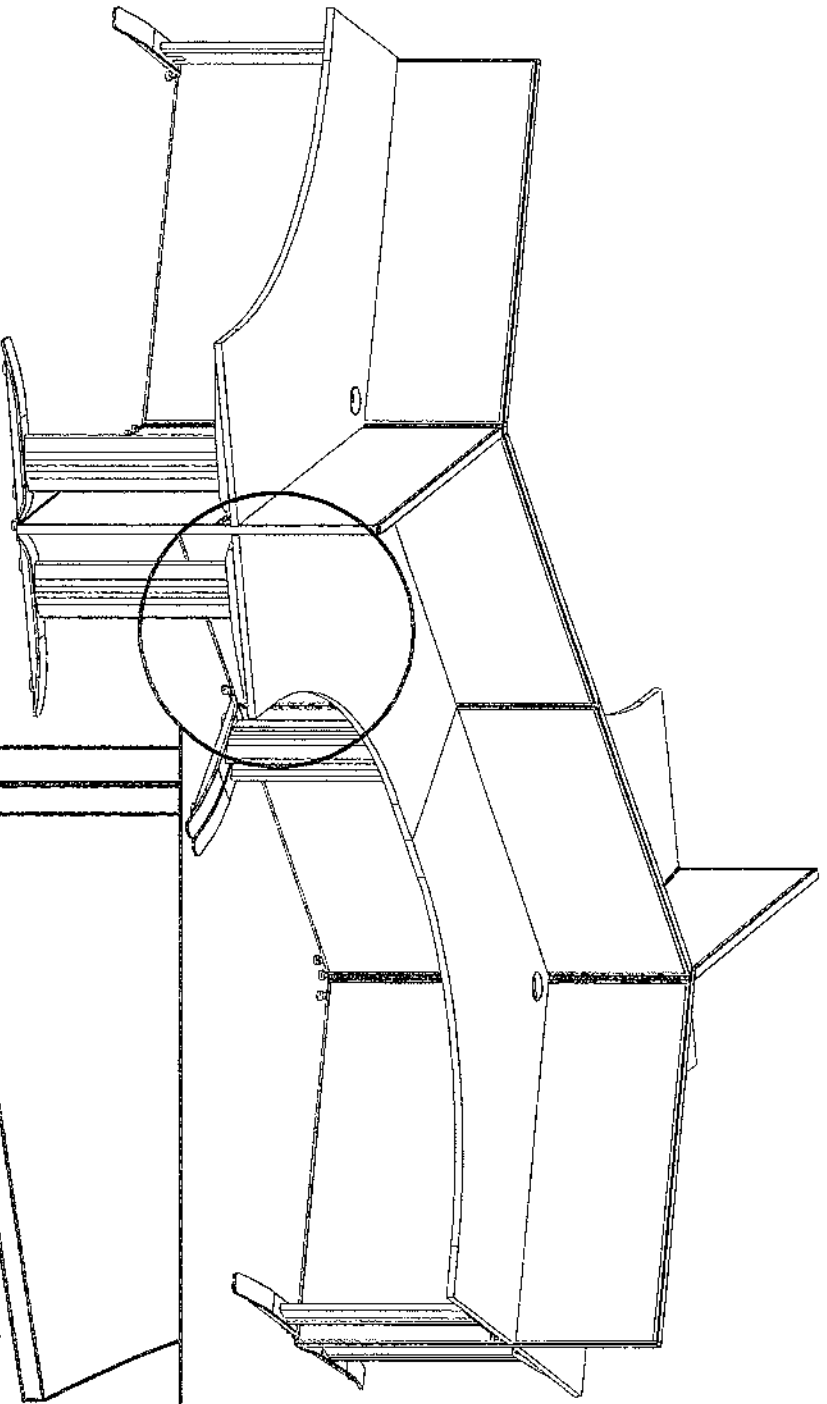

Set of 2

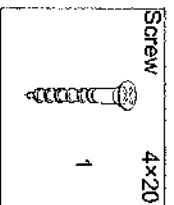
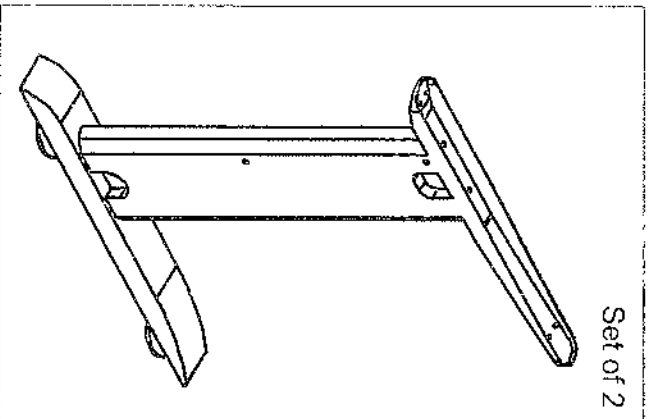

0. \*OPTIONAL STEP : Place table top upside down on a soft surface such as carpet or a rug. Place leg upside down on top in desired location, and using a pencil mark the locations of the screw holes. Do this for both sides. Create pre-drill holes using an electric drill.

\*NOTE: Make sure the side of the leg with 2 holes is facing in.

1. Use the 4 x screws provided to attach legs to top

## Desk Leg option

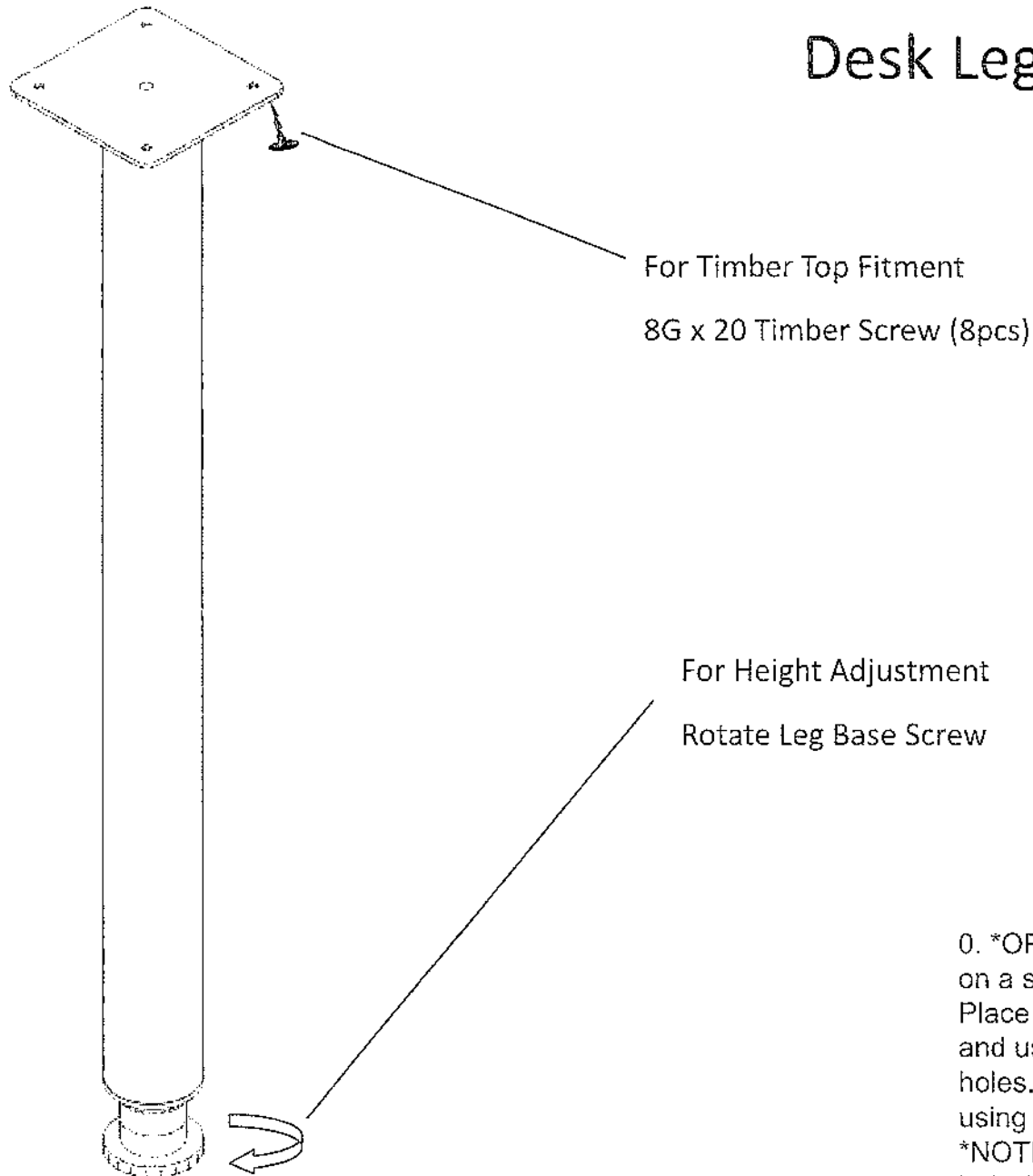

For Timber Top Fitment

8G x 20 Timber Screw (8pcs)

For Height Adjustment

Rotate Leg Base Screw

0. \*OPTIONAL STEP : Place table top upside down on a soft surface such as carpet or a rug.

Place leg upside down on top in desired location, and using a pencil mark the locations of the screw holes. Do this for all sides. Create pre-drill holes using an electric drill.

\*NOTE: Make sure the side of the leg with 2 holes is facing in.

1. Use the screws provided to attach legs to top